

C-Sense Logger

A small logger for monitoring pCO₂

The C-Sense logger collects temperature and the partial pressure of gas in liquids. These data are stored internally and uploaded to a computer via a USB cable. The C-Sense logger is self contained and able to function within a variety of liquid environments, including oil. The logger records time, date, internal temperature, and the partial pressure of gas in liquids. Sample rates can be set by the customer.

Applications

- Water quality
- Aquaculture
- Wastewater
- Reef
- Carbon capture storage
- Biofuel

Endurance & Samples

Sample Interval	Endurance (days)	Samples (CO ₂)
1 minute	1 week	10,000
10 minutes	20 days	3,000
60 minutes	120 days	3,000

Battery: Turner Designs Re-Chargeable Battery

Sensor Specifications

Accuracy	3% of full scale
Temperature Range	0 - 30 (°C)
Measurement Ranges	1000, 2000, 4000 ppm
Depth Rating	600 meters



Model of Design

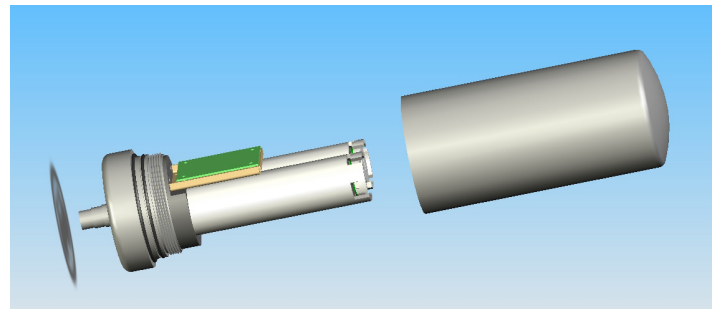

Software

ProOCO2Control allows the user to see the state of the logger as well as set sample rate.

ProOCO2Plot allows the user to see plots of the recorded measurements.

ProOCO2Concatenate gathers all the daily files into one CAT.txt file.